

M·COMP

Bring components to life



M·COMP ACCESSORIES

Stainless-steel accessories for food industry



Index

Features.....	3
Accessories overview.....	4
FT1 Wall mount bracket 1 axis.....	5
FT2 Wall mount bracket 2 axis.....	5
FT10 Wall mount for 65".....	6
FT11 Ceiling mount for 65".....	6
FTS1 Floor stand, 1.9 meters.....	7
FTS2 Keyboard arm.....	7
FTS3 Mounting bracket for printer shelf.....	8
FTS4 Printer box.....	8
FTS5 Shelf for printer.....	9
FTS6 Scanner box.....	9
FTS7 Shelf for scanner.....	10
FTS8 Ringbracket for floor stand.....	10
FTS9 Bracket for cable tray.....	11
FTS10 Cable tray, 3.0 meters.....	11
FTS11 Plate for power outlets.....	12
FTS15 Terminal bracket.....	12
FTS16 Main power cable, 3.2 meters, 230VAC EU.....	13
FTS17 IT box plate.....	13

Features

All accessories for the M-Comp terminals are made to be modular, flexible, and easy to clean.

All stainless-steel accessories are made in high quality AISI 316 which means they can be used in very tough environments like the food industry.

The round and closed floor stand with special made ring bracket offers flexibility and endless mounting solutions. The terminal and accessories can be adjusted in height and turned in the desired position making it ergonomic for each employee to handle.

Screws and plugs are included for each item.

Accessories overview

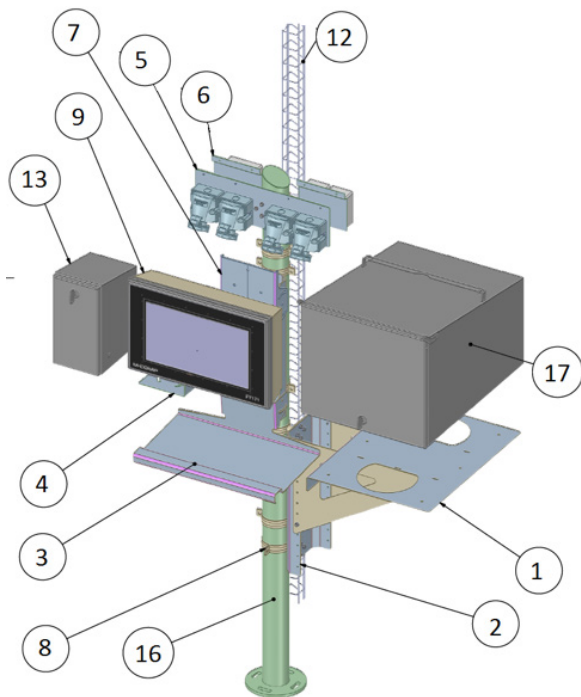

Pos. No.	M-Comp Parts no.	Description
1	14823	FTS5 Shelf for printer
2	14821	FTS3 Mounting bracket for printer shelf
3	14820	FTS2 Keyboard arm
4	14825	FTS7 Shelf for scanner
5	14829	FTS11 Plate for power outlets
6	14855	FTS17 IT Box plate
7	14841	FTS15 Terminal bracket
8	14826	FTS8 Ringbracket for floor stand
12	14828	FTS10 Cable tray 3.0 meters
13	14824	FTS6 Scanner box
16	14819	FTS1 Floor stand 1,9 meters
17	14822	FTS4 Printer box

All individual accessories are shown on subsequent pages.

The powerful stainless-steel FT150/171/240 terminals from M-COMP fit to the above accessories (see also the M-COMP FT terminal brochure).

FT1 Wall mount bracket 1 axis

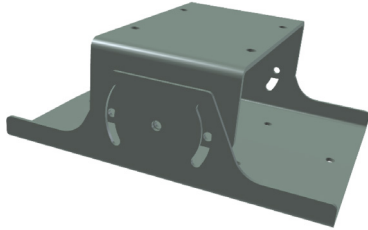

Features

- FT1 can be tilted 110°
- FT1 fits the FT150 and FT171 terminals
- FT1 is made in high quality AISI 316 stainless steel
- Screws and plugs are included

Ordering information

Parts no.	Description
14584	FT1 Wall mount bracket 1 axis

FT2 Wall mount bracket 2 axis

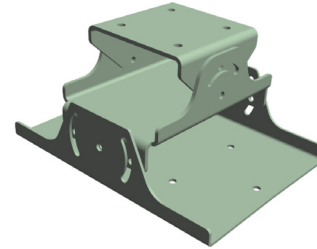

Features

- FT2 can be tilted 110° in both directions
- FT2 fits the FT150 and FT171 terminals
- FT2 is made in high quality AISI 316 stainless steel
- Screws and plugs are included

Ordering information

Parts no.	Description
14585	FT2 Wall mount bracket 2 axis

FT10 Wall mount for 65"

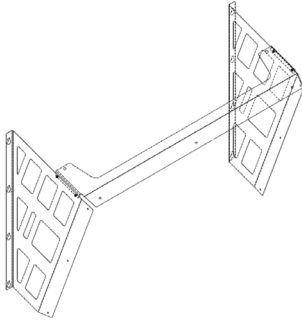

Features

- FT10 is a wall mounted bracket for the FT650 65" info terminal series
- FT10 is made in high quality AISI 316 stainless steel
- Screws and plugs are included

Ordering information

Parts no.	Description
14858	FT10 Wall mount for 65"

The powerful FT650 stainless-steel info terminal from M-COMP fit to the above accessory (see also M-COMP FT650 info terminal brochure).

FT11 Ceiling mount for 65"

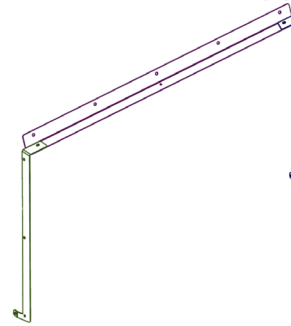

Features

- FT11 is a ceiling mounted bracket for the FT650 65" info terminal series
- FT11 is made in high quality AISI 316 stainless steel
- Screws and plugs are included

Ordering information

Parts no.	Description
14859	FT11 Ceiling mount for 65"

The powerful FT650 stainless-steel info terminal from M-COMP fit to the above accessory (see also M-COMP FT650 info terminal brochure).

FTS1 Floor stand, 1.9 meters

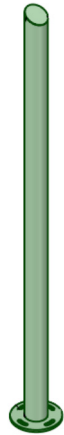
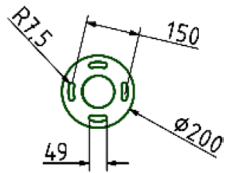

FTS2 Keyboard arm

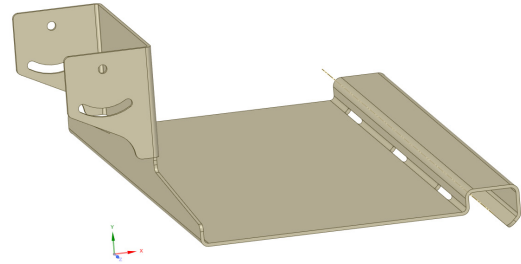

Features

- FTS1 is available in standard length 1.9 meters but can be delivered in other lengths on request
- FTS1 is fully welded at the top and bottom for easy cleaning
- FTS1 is made in high quality AISI 316 stainless steel

Ordering information

Parts no.	Description
14819	FTS1 Floor stand, 1.9 meters

Features

- FTS2 is used with the FTS3 mounting bracket
- FTS2 is made in high quality AISI 316 stainless steel
- Screws and plugs are included

Ordering information

Parts no.	Description
14820	FTS2 Keyboard arm

FTS3 Mounting bracket for printer shelf

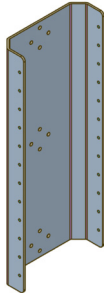

Features

- FTS3 used among other things with the FTS2 Keyboard arm
- FTS3 is made in high quality AISI 316 stainless steel
- Screws and plugs are included

Ordering information

Parts no.	Description
14821	FTS3 Mounting bracket for printer shelf, terminal and/or keyboard

FTS4 Printer box

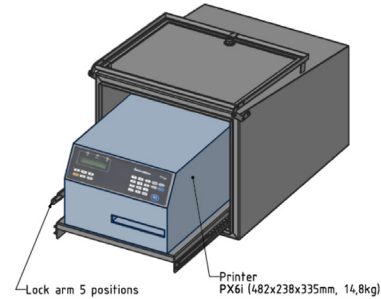

Features

- FTS4 is designed for the label printer PX6i
- FTS4 is IP65 water and dust prof
- FTS4 is made in high quality AISI 316 stainless steel
- The shelf can be locked in 5 positions
- Screws and plugs are included

Ordering information

Parts no.	Description
14822	FTS4 Printer box

FTS5 Shelf for printer

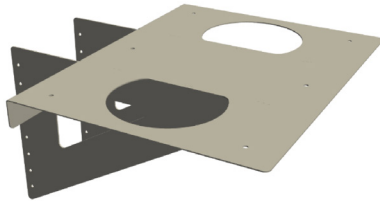

Features

- FTS5 is used together with the FTS4 Printer box
- FTS5 is made in high quality AISI 316 stainless steel
- Screws and plugs are included

Ordering information

Parts no.	Description
14823	FTS5 Shelf for printer box

FTS6 Scanner box

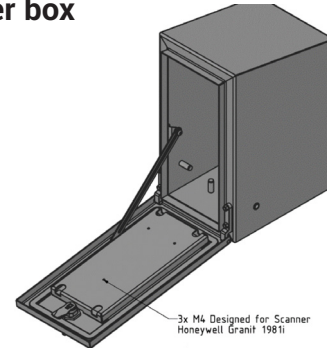

Features

- FTS6 is designed for the scanner Honeywell Granit 1981i
- FTS6 is IP65 water and dust prof
- FTS6 is made in high quality AISI 316 stainless steel
- Screws and plugs are included

Ordering information

Parts no.	Description
14824	FTS6 Scanner box

FTS7 Shelf for scanner box

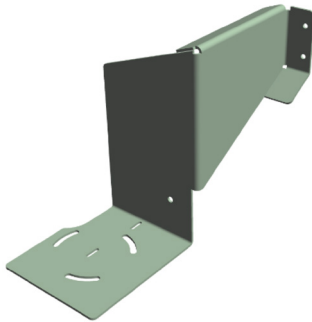

Features

- FTS7 is used together with the FTS6 Scanner box
- FTS7 is made in high quality AISI 316 stainless steel
- Screws and plugs are included

Ordering information

Parts no.	Description
14825	FTS7 Shelf for scanner box

FTS8 Ring bracket for floor stand

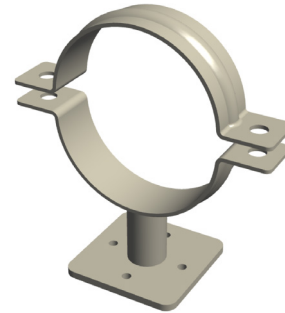

Features

- FTS8 is used together with the FTS1 Floor stand
- FTS8 is made in high quality AISI 316 stainless steel
- Screws and plugs are included

Ordering information

Parts no.	Description
14826	FTS8 Ring bracket for floor stand

FTS9 Bracket for cable tray

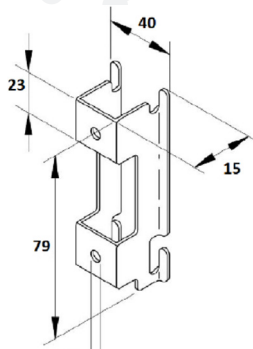

Features

- FTS9 is used together with the FTS10 Cable tray
- FTS9 is made in high quality AISI 316 stainless steel
- Screws and plugs are included

Ordering information

Parts no.	Description
14827	FTS9 Bracket for cable tray

FTS10 Cable tray, 3.0 meters

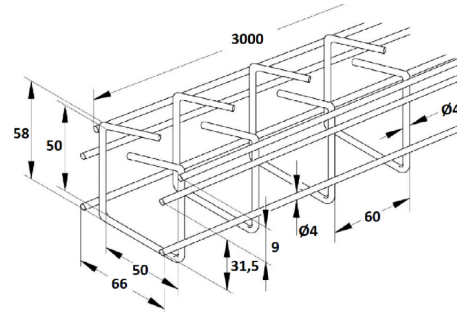

Features

- FTS10 is used together with the FTS9 Bracket for cable tray
- FTS10 is made in high quality AISI 316 stainless steel
- Screws and plugs are included

Ordering information

Parts no.	Description
14858	FTS10 Cable tray, 3.0 meters

FTS11 Plate for power outlets

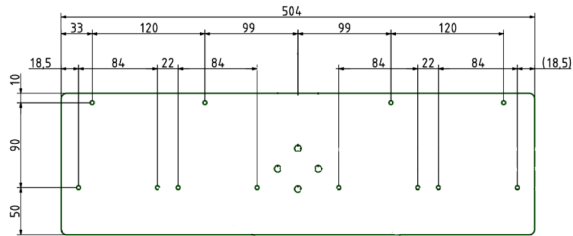

Features

- FTS11 is used together with the FTS8 Ring bracket and the FTS1 Floor stand
- FTS11 is made in high quality AISI 316 stainless steel
- Screws and plugs are included

Ordering information

Parts no.	Description
14829	FTS11 Plate for power outlets

FTS15 Terminal bracket

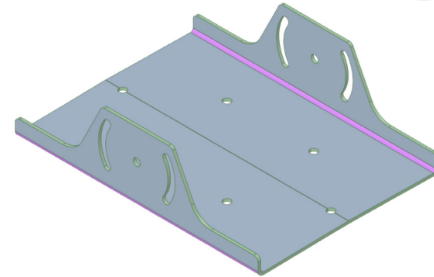

Features

- FTS15 are used together with the FT150 and FT171 stainless steel terminal
- FTS11 is made in high quality AISI 316 stainless steel
- Screws and plugs are included

Ordering information

Parts no.	Description
14841	FTS15 Terminal bracket

FTS16 Main power cable, 3.2 meters, 230VAC EU FTS17 IT box plate

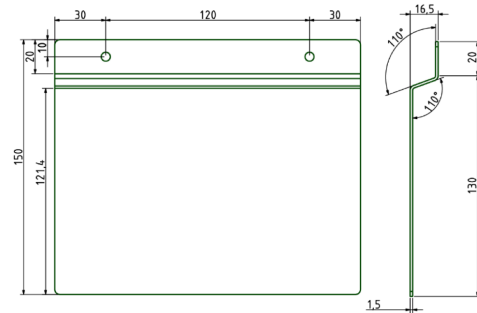

Features

- FTS16 Main power cable 1.9 meters, can be delivered in other lengths on request
- FTS16 can be used together with all M-COMP stainless-steel FT terminals

Features

- FTS17 is used together with the FTS11 Plate for power outlets
- FTS17 is made in high quality AISI 316 stainless steel
- Screws and plugs are included

Ordering information

Parts no.	Description
14598	FTS16 Main power cable, 3.2 meters, 230VAC EU

Ordering information

Parts no.	Description
14855	FTS17 IT box plate

The above accessory fit to the powerful stainless-steel terminal from M-COMP (see also M-COMP FT150/171/240/650 terminal brochure).





Demand



Idea



Development



Test



Production



Distribution